

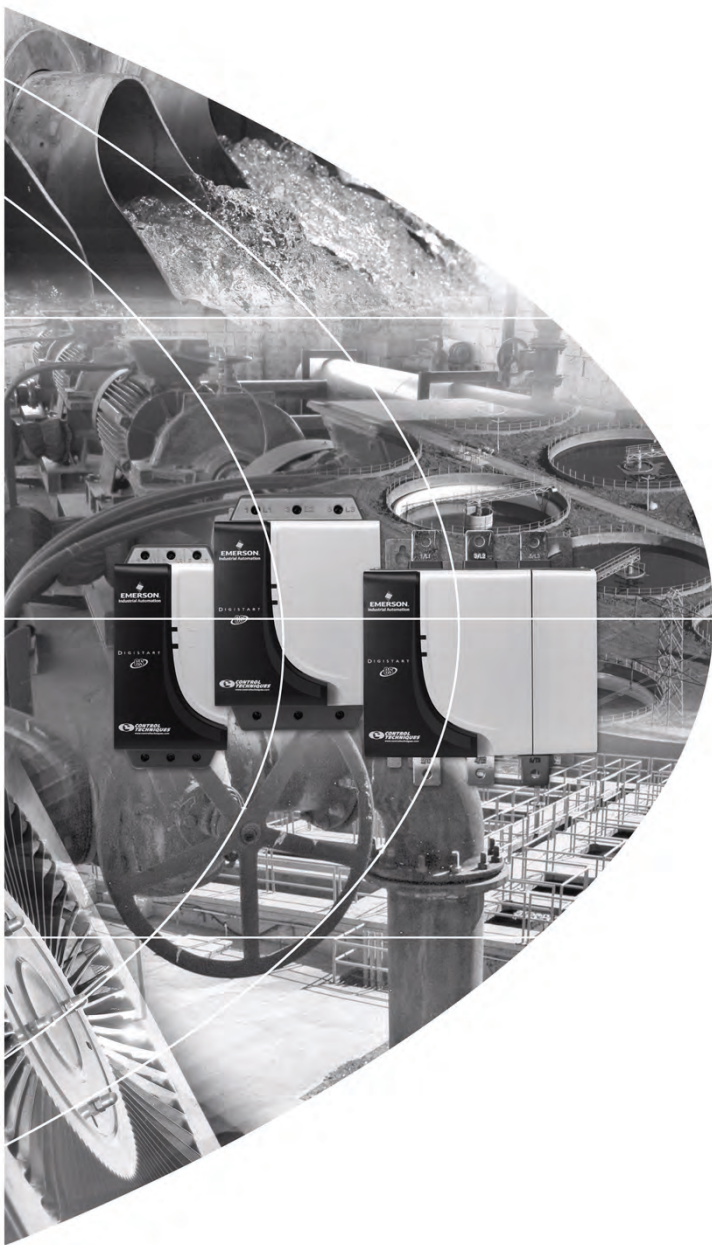

EMERSON[™]
Industrial Automation



User Guide

Remote Keypad

For Digistart soft starters

Part Number: 0477-0011-02
Issue: 2



www.controltechniques.com

General Information

The manufacturer accepts no liability for any consequences resulting from inappropriate, negligent or incorrect installation or adjustment of the optional parameters of the equipment or from mismatching the starter with the motor.

The contents of this guide are believed to be correct at the time of printing. In the interests of commitment to a policy of continuous development and improvement, the manufacturer reserves the right to change the specification of the product or its performance, or the content of the guide without notice.

All rights reserved. No parts of this guide may be reproduced or transmitted in any form or by any means, electrical or mechanical including, photocopying, recording or by an information storage or retrieval system, without permission in writing from the publisher.

Contents

1.	Introduction	4
2.	Installation	4
2.1	Mechanical installation	4
2.2	Connection.....	6
3.	Operation	7
3.1	Operation	7
3.2	Trip codes.....	7
4.	4-20 mA Analog Output	8
4.1	Overview.....	8
4.2	Calibration	8
4.3	Programming.....	8
5.	Troubleshooting.....	9
6.	Specifications.....	9

1. Introduction



Observe all necessary safety precautions when controlling the soft starter remotely. Alert personnel that machinery may start without warning.

It is the installer's responsibility to follow all instructions in this manual and to follow correct electrical practice. Use all internationally recognised standard practice for RS485 communications when installing and using this equipment.

General Description

The Remote Keypad allows remote operation of the soft starter, and offers the following functionality:

- Operational control (Start, Stop, Reset, Quick Stop)
- Starter status monitoring (Ready, Starting, Running, Stopping, Tripped)
- Performance monitoring (motor current, motor temperature)
- Trip code display
- 4-20 mA analog output (motor current)
- Optional RS485 network connection ¹

¹ The Remote Keypad can act as a gateway device for connection to an RS485 serial communications network, allowing remote control of a motor using Modbus RTU or standard AP ASCII communications protocol. For further information, please refer to the Modbus Module Instructions.

2. Installation

This section describes how to install the Remote Operator for basic control and monitoring of a soft starter. The Remote Operator is pre-configured to control a soft starter once control supply power is applied to both devices. For basic operation, no parameter adjustments are required on the Remote Operator or the soft starter.

In order to use the Remote Operator's 4-20 mA analog output to monitor motor current, follow the instructions in the section *4-20 mA Analog Output* on page 7.



Remove mains and control voltage from the soft starter before attaching or removing accessories. Failure to do so may damage the equipment.

2.1 Mechanical installation

2.1.1 For use with Digistart CS

In order to use the Remote Keypad with Digistart CS soft starters, a Remote Keypad Module or Modbus Module must be installed to the starter.

Figure 2-1 Attach the module to the starter

1. Remove control power and mains supply from the soft starter.
2. Attach the module to the soft starter as illustrated.
3. Connect the Remote Keypad to the module.

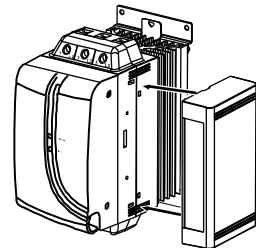

2.1.2 Mounting

The Remote Keypad is rated IP54 or NEMA 12 ¹ when mounted correctly in accordance with these instructions. It is intended for use on the flat surface of a panel, with all external wiring connected from behind the panel.

The Remote Keypad is supplied with a mounting bracket and four fasteners. The built-in gasket seal guarantees protection from outside the panel.

Select the panel location of the Remote Keypad. The required panel cutout is 92 mm x 92 mm. Place the Remote Keypad through the cutout and locate the mounting bracket at the rear of the panel onto the four studs. Use the four fasteners to tighten the mounting bracket up to the rear of the panel.

¹ For use on a flat surface of a NEMA 1 or NEMA 12 enclosure.

Figure 2-2 Mounting

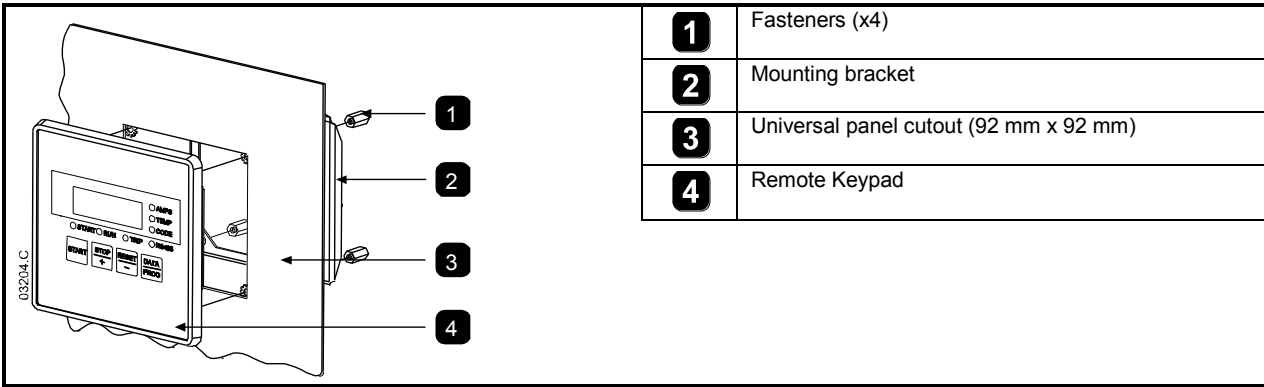

2.1.3 Dimensions

Figure 2-3 Unit dimensions

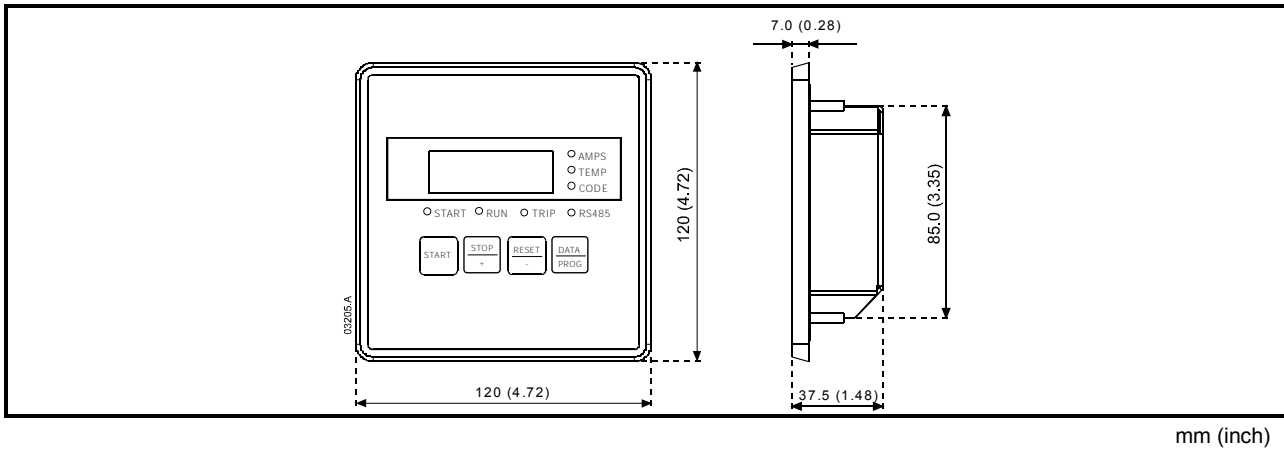

2.2 Connection

The Remote Keypad requires a minimum of three electrical connections - the external power supply, the chassis ground and the RS485 Starter port. All external wiring, except the chassis ground (M4 stud provided), is connected to spring operated clamp connector terminals with a maximum wire size of 2.5 mm². No special tools are required.

Once the Remote Operator Module has been installed, wire between the Remote Operator and the module.

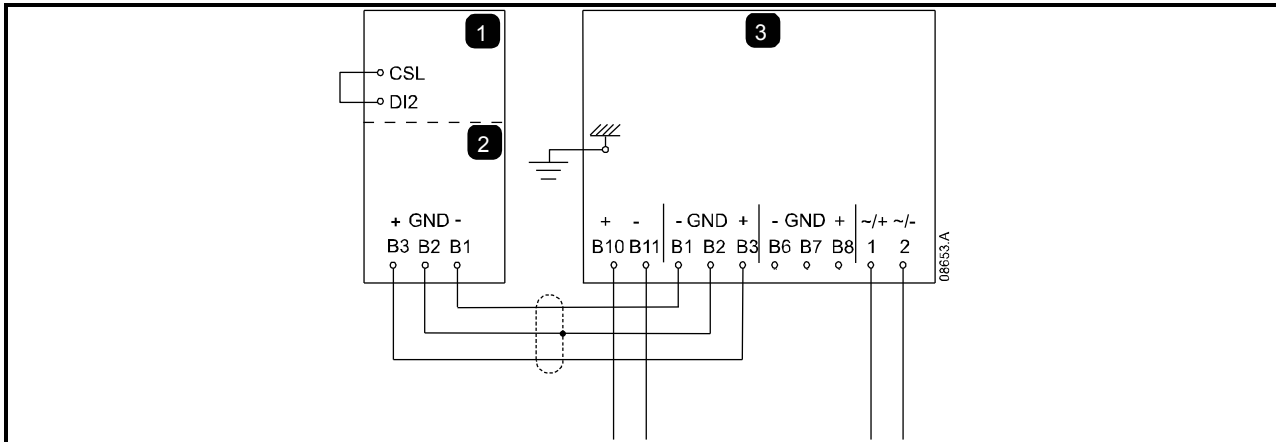

1	Digistart CS
2	Remote Operator Module - RS485 serial port
3	Remote Operator
	B10, B11: 4-20 mA analog output (motor current)
	B1, B2, B3: RS485 connection to starter/module
	B6, B7, B8: RS485 connection to network
	1, 2: power supply (18 to 30 Vac/DC)

Digistart CS: For the Remote Operator to accept serial commands, a link must be fitted across terminals CSL-DI2 on the soft starter.

2.2.1 Grounding and shielding

Twisted pair data cable with ground shield is recommended. The cable shield should be connected to the GND device terminal at both ends and one point of the site protective ground.

2.2.2 Termination resistors

In long cable runs prone to excessive noise interference, termination resistors should be installed between the data lines at both ends of the RS485 cable. This resistance should match the cable impedance (typically 120 Ω). Do not use wire wound resistors.

3. Operation

3.1 Operation

The Remote Keypad performs all soft starter functions except programming of the soft starter. The Remote Keypad can only be used to program its own parameters.

Figure 3-1 Keypad and display

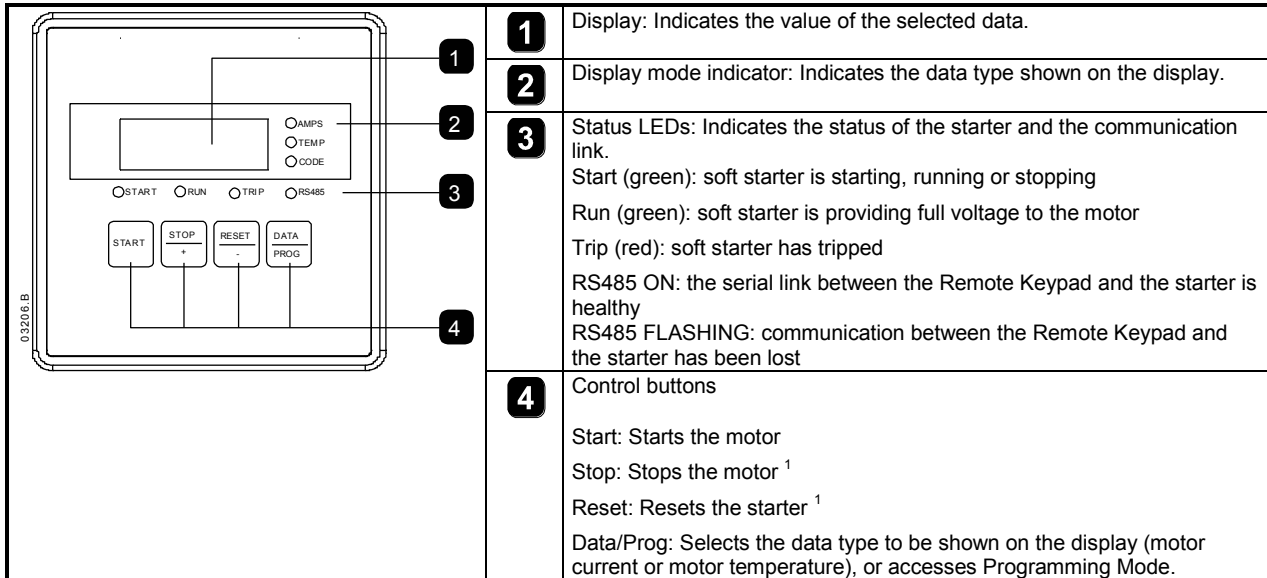

¹ Simultaneously pressing the **STOP** and **RESET** buttons initiates a quick stop, which immediately removes voltage from the motor, ignoring any soft stop time set on the starter.

3.2 Trip codes

If the soft starter trips, the CODE and TRIP LEDs illuminate and the relevant trip code is reported on the Remote Keypad display.

Table 3-1 Trip messages

Code	Description
1-1	Excess start time
1-2	Motor overload (thermal model)
1-3	Motor thermistor
1-4	Current imbalance
1-5	Frequency
1-6	Phase sequence
1-8	Power circuit
1-b	Bypass overload
1-C	Communications failure between module and starter
1-H	Forced communications trip from the network master

4. 4-20 mA Analog Output

4.1 Overview

The Remote Keypad has a 4-20 mA analog output for monitoring motor current. The 4-20 mA output is available on terminals B10, B11.

The analog output signal spans from 4 mA when the motor current is zero (when the soft starter is not running) to 20 mA when the motor current is 125% of the Motor FLC setting in the Remote Keypad (Pr 6).

4.2 Calibration

The Remote Keypad Motor FLC parameter (Pr 6) must be adjusted to match the Motor FLC setting in the soft starter.

The lower end of the analog output signal can be calibrated using the Remote Operator Analog Output 4 mA Offset parameter (Pr 7). This is set to give a 4 mA output signal when the motor current is zero.

The 4-20 mA analog output has an accuracy of $\pm 10\%$. It is not designed for process signal control and should only be used for motor current monitoring and metering.

4.3 Programming

When the 4-20 mA output is being used, the Remote Operator's Motor FLC and Analog Output 4 mA Offset parameters (Parameters 6 and 7) must be set appropriately (see *Calibration*). Programming can only be carried out while the soft starter is not running.

4.3.1 Programming procedure

1. To enter Programming Mode, hold down the Data/Prog pushbutton for four seconds. The default value of the first parameter will be displayed.
2. Use the Data/Prog pushbutton to advance to the next parameter.
3. Use the Stop and Reset pushbuttons to adjust parameter values.

Programming Mode closes when the Data/Prog pushbutton is pressed after Pr 9.

NOTE There is a 20 second timeout when the Remote Keypad is in Programming Mode. Programming Mode will automatically close if no input is registered for 20 seconds. Any changes already made will be saved.

4.3.2 Programmable parameters

Table 4-1 Programmable parameters

Parameter Number	Description	Default Setting	Adjustable Range
1	RS485 Network Baud Rate ¹	4	
2	RS485 Network Satellite Address ¹	20	
3	RS485 Network Timeout ¹	0	
4	RS485 Network Protocol ¹	1	
5	Modbus Protocol Parity ¹	0	
6	Motor FLC (A)	10	1 to 2868
7	Analog Output 4 mA Offset (%)	100	80 to 120
8	Start, Stop, Quick Stop function disable	0	0 = Remote Keypad start, stop, quick stop function enabled. 1 = Remote Keypad start, stop, quick stop function enabled. 2 = Remote Keypad start, stop, quick stop function disabled. ² 3 = Remote Keypad start, stop, quick stop function disabled. ²
9	Current \div 10	0	0 = off (required for Digistart CS) 1 = on (not suitable for Digistart CS)

¹ Pr 1 to 5 only apply when the Remote Keypad is being used as a Modbus or AP ASCII network gateway. See the Modbus Module Instructions for details.

² Remote Keypad Reset pushbutton is always enabled.

NOTE Remote Keypad Pr 9 *Current \div 10* normalises the displayed current and analog output for models IS0023B to IS0430C. Use Pr 9 in conjunction with Pr 6 *Motor FLC* as follows:

1. Set Pr 6 to a value 10 times greater than the actual motor nameplate FLC (e.g. for actual FLC = 4.6 A, set Pr 6 to 46).
2. Set Pr 9 = 1.

5. Troubleshooting

Table 5-1 General faults

Display Indication	Problem	Possible Solution
No display	No control voltage	Check that correct voltage is present at terminals 1, 2.
AMPS or TEMP LED flashing	Soft starter in restart delay mode	Wait for the restart delay (programmed in the soft starter) to elapse.
Four dashes on display and RS485 LED flashing	The Remote Keypad has detected a loss of communication on the RS485 link to the soft starter	Verify and solve the cause for loss of communication. If communication is restored before the soft starter trips, the display will return to active status and the RS485 LED will illuminate. If communication is restored after the soft starter has tripped, the display will indicate the trip code. Use the Reset button to reset the soft starter fault.
-	Incorrect or no 4-20 mA analog output signal	Check the correct voltage is present at terminals 1, 2. Check that correct polarity is used at terminals B10, B11. Check that the Motor FLC, Analog Output 4 mA Offset and Current ÷ 10 parameters are set correctly.
-	The motor cannot be started	Check that control voltage is connected to the starter. <ul style="list-style-type: none"> If connected to a Digistart CS, check that terminals CSL-DI2 on the starter are linked. Pr 8 on the Remote Keypad must be set to 0 or 1.

6. Specifications

Enclosure

Front Panel Height	120 mm
Front Panel Width	120 mm
Inside Panel Depth (when mounted).....	30 mm (max)
Panel Cutout	92 mm ²
Weight.....	450 g

Power supply

Voltage.....	18 - 30 Vdc/Vac (50/60 Hz)
Consumption	100 mA (max - steady state)
Connection (Terminals 1, 2)	2 pole spring clamp connector terminals

RS485 serial network port (optional)

RS485 Network Interface	AP ASCII or Modbus RTU protocol (selectable)
Connection (Terminals B6, B7, B8)	3 pole spring clamp connector terminals

RS485 serial starter port (soft starter connection)

RS485 Soft Starter Interface.....	AP ASCII protocol as standard
Connection (Terminals B1, B2, B3)	3 pole spring clamp connector terminals

Analog output

Motor Current Monitoring Interface	4-20 mA (max burden 200 Ω)
Connection (Terminals B10, B11).....	2 pole spring clamp connector terminals

Sundry

Enclosure Rating	IP54 or NEMA 12 when correctly panel mounted
Pollution Degree	Pollution Degree 3
Operating Temperature	- 5 °C / + 60 °C
Relative Humidity	5 to 95% (max non-condensing)

This product has been designed as Class A equipment. Use of this product in domestic environments may cause radio interference, in which case the user may be required to employ additional mitigation methods.

Approvals

CE	IEC 60947-4-2
UL / C-UL	UL 508
C✓	IEC 60947-4-2

0477-0011-02



710-08011-00B